

## Ice Makers

### Half Dice Ice, 220kg/24h, 230kg bin, air-cooled

ITEM # \_\_\_\_\_

MODEL # \_\_\_\_\_

NAME # \_\_\_\_\_

SIS # \_\_\_\_\_

AIA # \_\_\_\_\_



**730296 (IHD220M230SNP)** Ice maker, half dice ice, 220 kg/24h, modular, 230kg stainless steel collection bin, air-cooled

### Short Form Specification

#### Item No.

Air cooled half dice maker, modular with 230kg bin. AISI 304 stainless steel exterior, food grade and internal ice container in ABS, copper evaporator ensure safe contact with ice. Fully automatic in operation and easy cleanability thanks to the automatic cleaning system. The ice making method guarantees continuous and reliable production, crystalline and hygienically pure ice cubes that quickly cool the drinks down. Electronic board controls the set parameters and sensitive touch-press panel with 2 speed regulation of ice production. Bin with internal corner for easy cleaning and it is fully insulated. Supplied with flexible water supply, drain hoses and scoop. Hydrocarbon refrigerant gas R290 for the lowest environmental impact.

### Main Features

- The ice making method guarantees a continuous and reliable production.
- Easy cleanability guaranteed by an automatic system: the cleaning switch activate the circulation and the rinse of water; at the end of the cycle just swithed again to start producing ice.
- The ice-making method guarantees ice cubes that quickly cool the drinks down.
- Water consumption and productivity calculated using 15°C water temperature and 21°C ambient temperature.
- Fully automatic in operation.
- Rounded internal corners of the bin assure ease of cleaning.
- Food grade ABS interior.
- Suitable for gravity drain only.
- Bin included.
- Compliant to CE requirements for safety.

### Construction

- Reliability guaranteed by the quality of the construction materials used (front, top and sides in 304 AISI stainless steel) and the sophisticated product and process technology involved.
- Thanks to a vertical evaporator, the appliance guarantees considerable ice production in a short time: the cubes detach individually and fall into the bin, perfectly separated from each other and of equal size (6 g).
- The sprayers are easy to take away, permit a simple flowing and prevent limestone formation.
- AISI 304 stainless steel exterior.
- Copper evaporator ensures a safe contact with ice.
- Internal ice containers in ABS.
- Hygienical plastic spray arms removable without the use of tools.
- Supplied with flexible water supply, drain hoses and scoop.
- Easy access to the main components for maintenance.
- Plug as standard (schuko type).

### Sustainability

- Hydrocarbon refrigerant gas R290 for the lowest environmental impact (GWP=3) - CFC and HCFC free.
- Reduced energy consumption by fully insulated storage bin.

APPROVAL: \_\_\_\_\_

**Rear side**

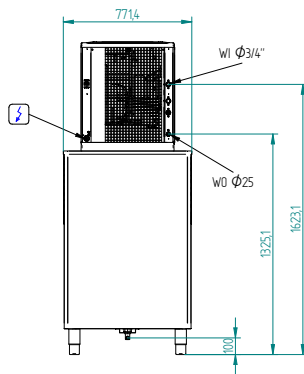

**Side**

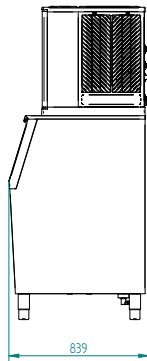

- CW11** = Cold Water inlet 1 (cleaning)
- D** = Drain
- EI** = Electrical inlet (power)

**Front**

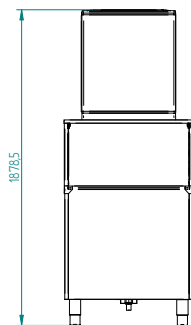

**Other**

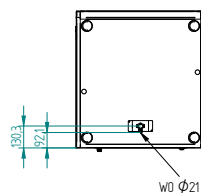

**Electric**

Supply voltage:  
730296 (IHD220M230SNP) 220-240 V/1N ph/50 Hz  
Electrical power max.: 0.79 kW

**Capacity:**

Bin capacity: 230 kg

**Key Information:**

External dimensions, Width: 762 mm  
External dimensions, Depth: 819 mm  
External dimensions, Height: 1676 mm  
Net weight: 85 kg  
Output: 220 kg/day  
Kind of cube: Ice Cube 6 g

**Sustainability**

Refrigerant type: R290  
Refrigerant weight: 135 g  
Water consumption: 12 lt/hr